



LEGIOMIX® ELECTRONIC MIXING VALVE

CALEFFI
Hydronic Solutions



Plumbing

Protecting the system to protect your water



PRODUCT FEATURES

- **Market's highest rated flow capacity:**
DZR low-lead brass body, full-port ball valve, ¾" to 3" connections, 2.2 to 537 gpm flow rates.
- **Thermal disinfection programs:**
Calendar based programs for scheduling circuit thermal disinfection to kill Legionella.
- **Complete kit:**
Everything needed for quick installation, including valve, actuator, LCD/LED controller, mix outlet sensor and return temperature sensor.
- **Self cleaning:**
Automatic daily ball rotation to flush scale and debris, ensuring smooth operation.
- **Union pipe fittings:**
¾" through 2" models have all-union connections for easy maintenance and service without piping modifications.
- **BAS-ready:**
Integral Modbus is standard with an optional Modbus-BACnet gateway for remote access to building automation integration.

Advanced Mixing Control

LEGIOMIX® is an advanced electronic mixing valve with digital control of temperature for commercial domestic hot water systems. The daily exercise function keeps the ball valve free of scale build-up to ensure smooth operation. Rated highest in the market for flow capacity, this feature packed product also has an industry exclusive calendar-based scheduling program for automatic circuit thermal disinfection.

PRODUCT RANGE - LEGIOMIX®

SIZE	Cv	MIN. FLOW (GPM) *	DESIGN FLOW (GPM) **	MAX. FLOW (GPM) ***	CODE		
					NPT	SWEAT	PRESS
¾"	9.7	2.2	27	43	600054A	600059A	600056A
1"	21	3.1	58	94	600064A	600069A	600066A
1¼"	24	4.4	66	107	600074A	600079A	600076A
1½"	34	6.6	93	152	600084A	600089A	600086A
2"	47	8.8	131	215	600094A	600099A	600096A
2½"	105	17	288	470	600060A flanged	--	--
3"	120	22	329	537	600080A flanged	--	--

*To ensure stable operation and accurate temperature control. Minimum flow is 0 gpm when recirculation flow rate is \geq the valve size minimum flow rating.

**Suggested maximum flow rate for optimum modulating control (at 7.5 psid pressure drop).

***Maximum recommended differential pressure is 20 psid for smooth and quiet operation. Inlet port check valves are available for field installation, code NA10366 (1", 1¼") and NA10367 (1½", 2").

Meets requirements of CSA Z317.1 Special Requirement for Plumbing Installations in Health Care Facilities.



PERFORMANCE

MAX. OPERATING PRESSURE	150 psi (10 bar)
SETTING TEMPERATURE RANGE	70 — 185°F (20-85°C)
DISINFECTION TEMP. RANGE	100 — 185°F (40-85°C)
MAX. HOT WATER INLET TEMP.	212°F (100°C)

WIRING DIAGRAM

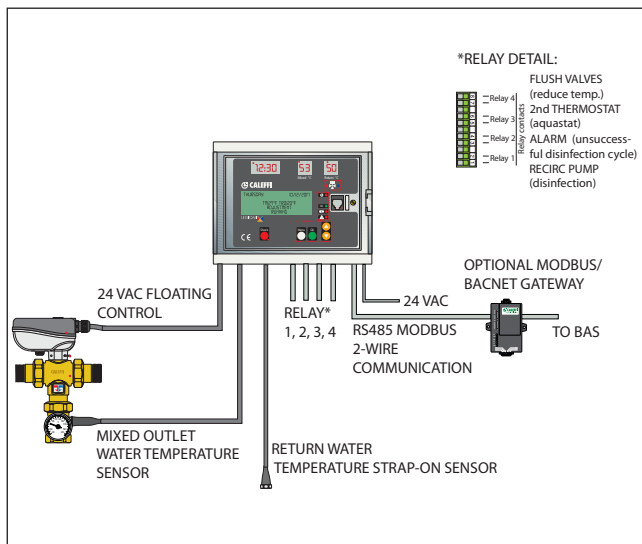

Caleffi Partner:

PACKAGE CONTENTS

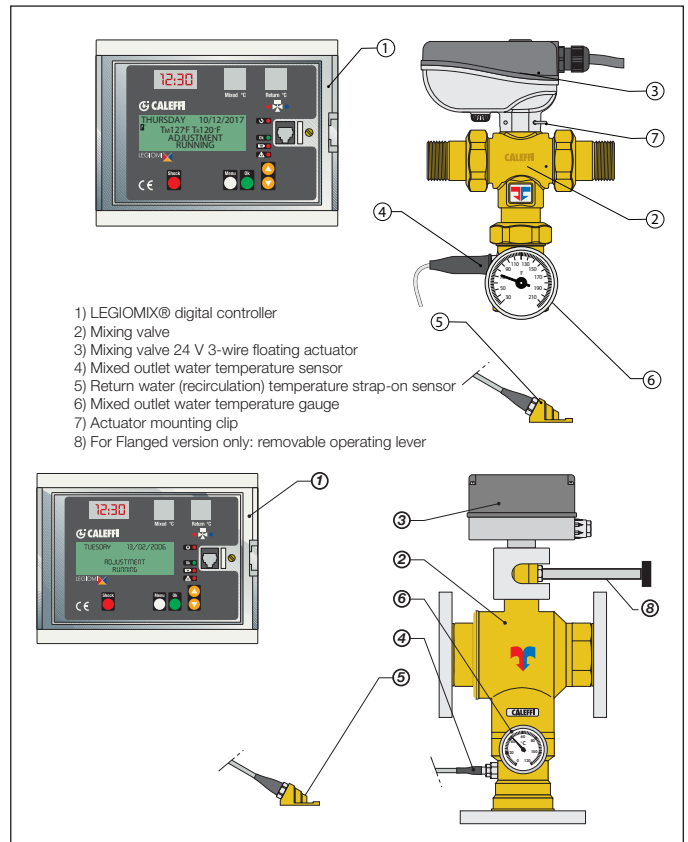

EXAMPLE APPLICATION DIAGRAM

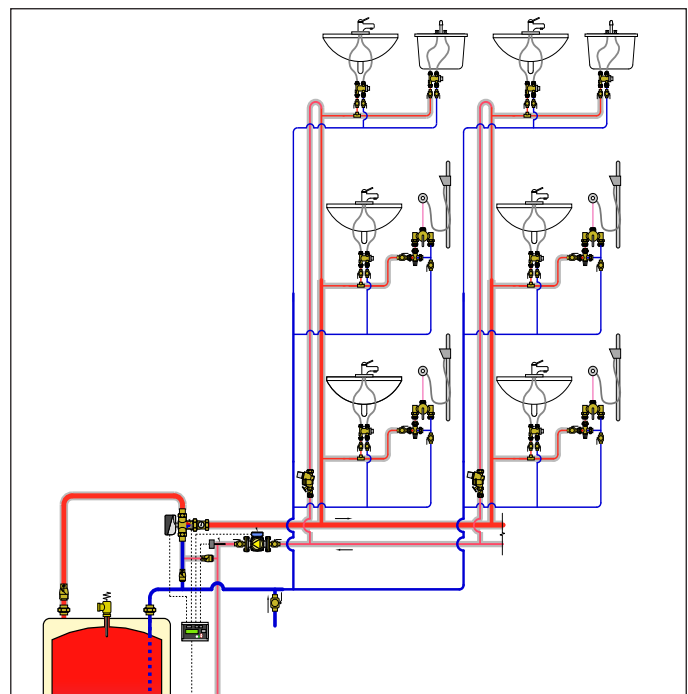

CALEFFI
Hydronic Solutions

03532-20.1 NA

WE RESERVE THE RIGHT TO CHANGE OUR PRODUCTS AND THEIR RELEVANT TECHNICAL DATA, CONTAINED IN THIS PUBLICATION, AT ANY TIME AND WITHOUT PRIOR NOTICE.

Caleffi North America, Inc.
sales@caleffi.com · www.caleffi.com
© Copyright 2020 Caleffi North America, Inc.